

TRANSVERSE / CONSTRUCTION JOINTS TO BE CONTINUOUS THROUGH OPEN INVERT, BUS BAY & KERB

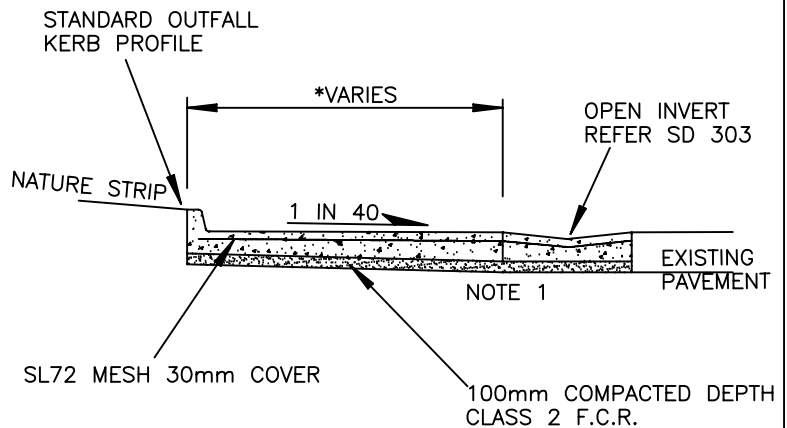

SECTION A-A
NOT TO SCALE

NOTES

- 1 CONTINUE AG DRAIN BENEATH OPEN INVERT WITH ϕ 100 NOM. CL.400 PERFORATED POLYETHYLENE TO AS2439. BACKFILL AG USING NO FINES CONCRETE
- 2 AG. DRAINS TO CONNECT TO NEAREST DOWNSTREAM PIT
- 3 ALL CONSTRUCTION / TRANSVERSE JOINTS TO USE ϕ 16 X 300 DOWELS @ 200 CENTRES, 150 IN 150 OUT.
- 4 TRANSVERSE JOINT -----

NOT TO SCALE

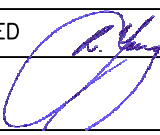
 City of Whittlesea		
PARTIALLY INDENTED BUS BAY		SD 604
APPROVED 	REV. DATE 30/9/2003	REV C