

01 ANIMAL EXCLUSION FENCE - SECTION
SCALE: 1:75 @ A4

QUICK SPECIFICATION	
APPLICATION OR TYPICAL LOCATION:	TO BE CONFIRMED WITH COUNCIL REPRESENTATIVE
PRODUCT:	2000mm HIGH ANIMAL MESH FENCE
SUPPLIER:	CONTRACTOR TO NOMINATE
MATERIAL AND FINISH:	POSTS: 150mm ACQ TREATED PINE POST PICKETS: STEEL STAR PICKET FENCING: HOT DIPPED GALVANISED HIGH TENSILE FENCING WIRE HIGH MESH
FIXING / FOOTING:	INGROUND CONCRETE FOOTING
ADDITIONAL OPTIONS:	NOT APPLICABLE
AUSTRALIAN STANDARDS:	
STANDARD DRAWING CROSS REFERENCES:	

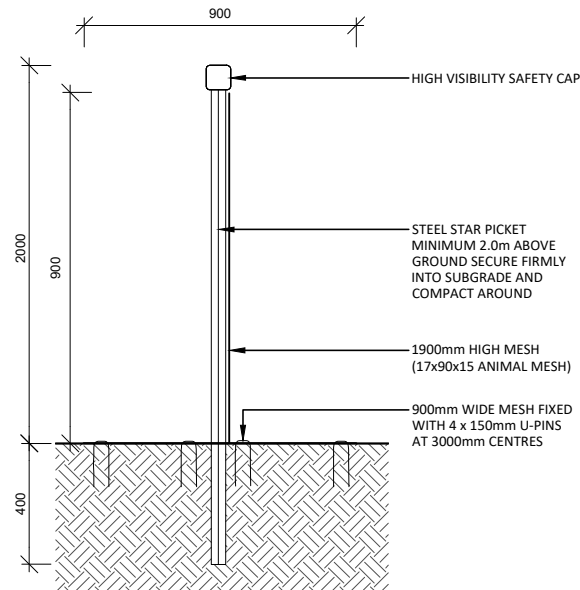

02 STEEL STAR PICKET WITH MESH SKIRT AND BASE - SECTION
SCALE: 1:50 @ A4

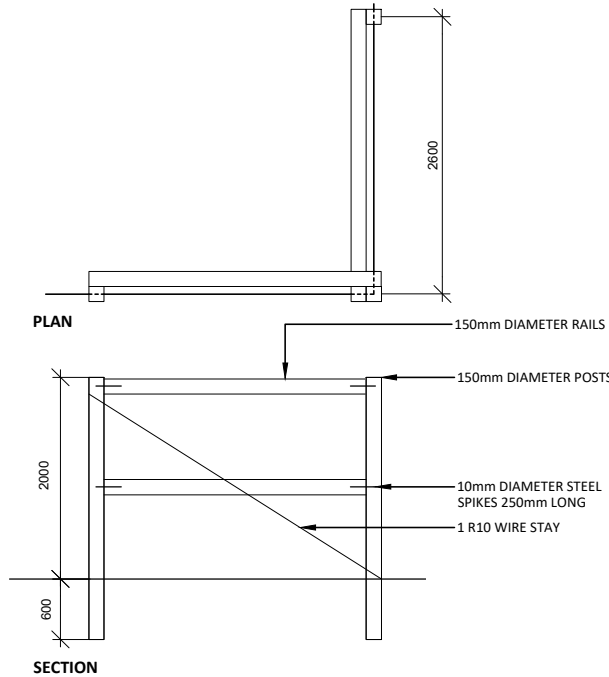

03 STRAINING POST CORNER ASSEMBLY
SCALE: 1:75 @ A4

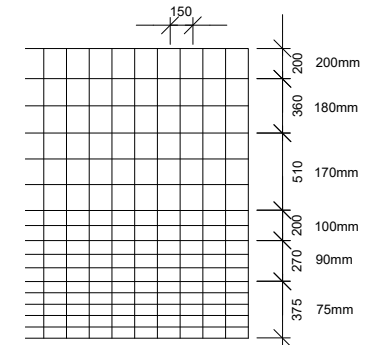

04 MESH SIZE
SCALE: 1:50 @ A4

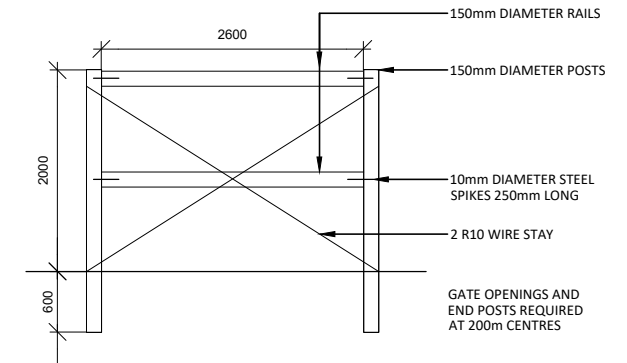

05 STRAINING POST ASSEMBLY - SECTION
SCALE: 1:75 @ A4

Drawn	HK
Checked	AC, AN
Approved	JG
Date	JUNE 2023



STANDARD DETAIL
LANDSCAPE CONSTRUCTION DETAIL
ANIMAL EXCLUSION FENCE DETAIL

DWG NO.
SDL.2.15

REVISION_A