

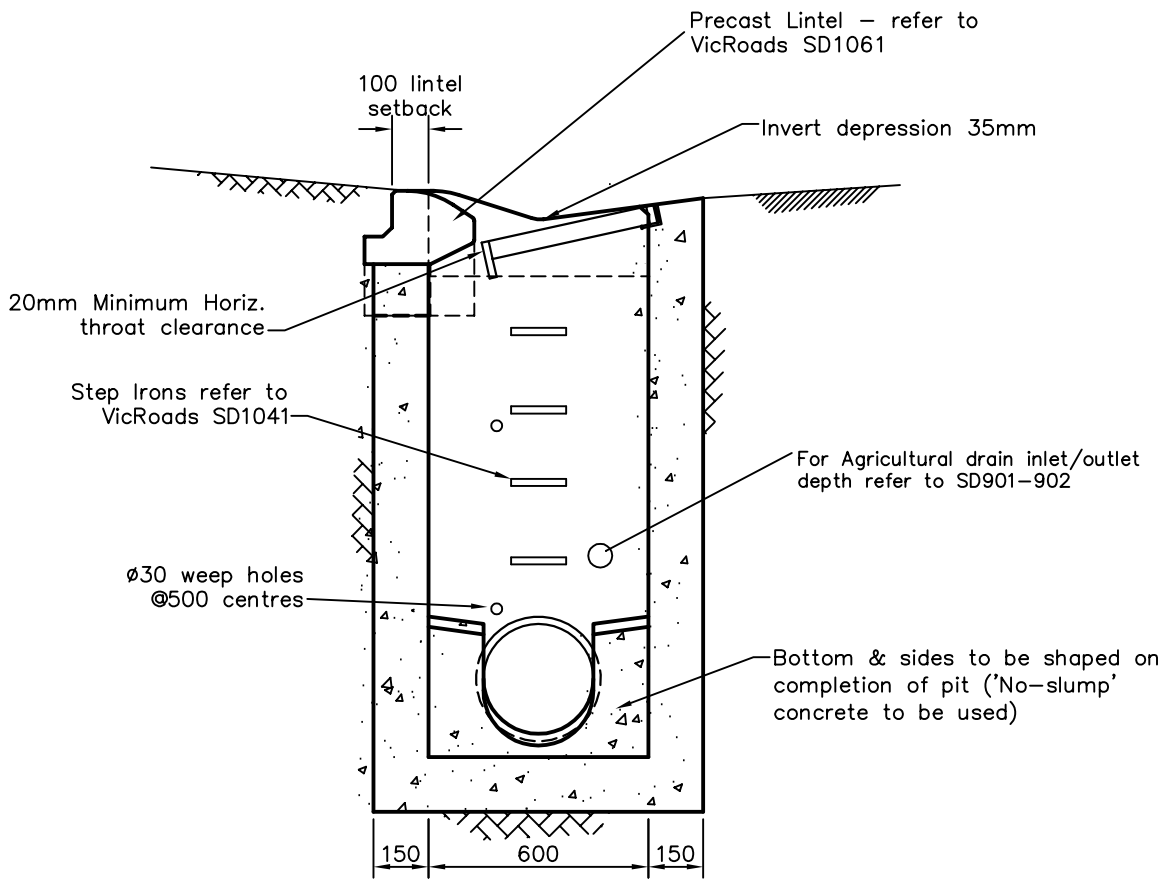

PLAN



SECTION A-A

NOTES

1. INSIDE DIMENSIONS OF SIDE ENTRY PITS 900 x 600 FOR PIPES NOT EXCEEDING 450 ϕ - PIPE C/L 300 FORWARD OF B.O.K.
2. PIT WALLS 150 THICK EXCEPT WHERE PITS GREATER THAN 1800 DEEP OR PIPE ϕ EXCEEDS 450 THEN WALLS SHALL BE 200 THICK CONCRETE
3. PITS 900 DEEP & OVER TO HAVE STEP IRONS FITTED-REFER VICROADS SD1061
4. SUBJECT TO APPROVAL, PRECAST PITS MAY BE SUBSTITUTED

 City of Whittlesea		
GRATED SIDE ENTRY PIT FOR ROLLOVER KERB AND CHANNEL		SD 217
APPROVED	REV. DATE 17/07/2003	REV B