

TRANSVERSE / CONSTRUCTION JOINTS TO BE CONTINUOUS THROUGH OPEN INVERT, BUS BAY & KERB

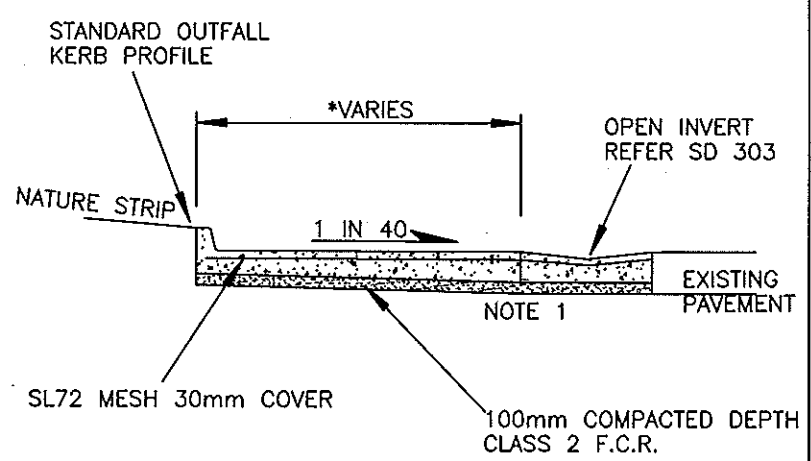

SECTION A-A
NOT TO SCALE

NOTES

- 1 CONTINUE AG DRAIN BENEATH OPEN INVERT WITH $\phi 100$ NOM. CL.400 PERFORATED POLYETHYLENE TO AS2439. BACKFILL AG USING NO FINES CONCRETE
- 2 AG. DRAINS TO CONNECT TO NEAREST DOWNSTREAM PIT
- 3 ALL CONSTRUCTION / TRANSVERSE JOINTS TO USE $\phi 16$ X 300 DOWELS @ 200 CENTRES, 150 IN 150 OUT.
- 4 TRANSVERSE JOINT -----

NOT TO SCALE

City of Whittlesea		
FULLY INDENTED BUS BAY		SD 605
APPROVED <i>[Signature]</i>	REV. DATE 13/10/11	REV D

NOTE 1